

RECUMBENT BIKE

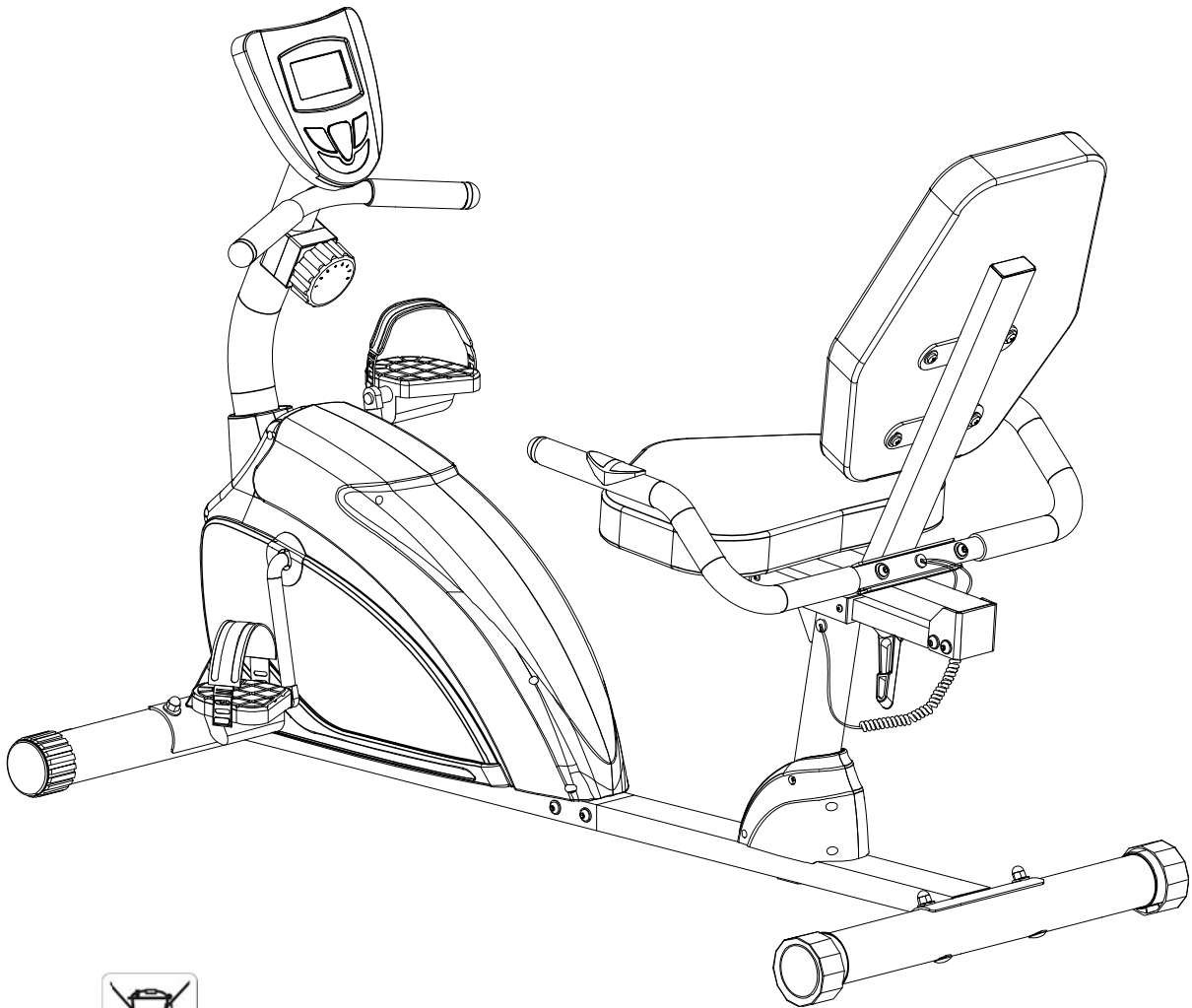

IMPORTANT: Read all instructions carefully before using this product.
Retain this owner's manual for future reference.
The specifications of this product may vary from this photo, subject to
change without notice.

TABLE OF CONTENTS

SERVICE-----	2
TABLE PLACEMENT-----	3
PRODUCT SAFETY-----	4
OVERVIEW DRAWING-----	5
PARTS LIST-----	6
ASSEMBLY GROUP-----	8
GROUP LIST-----	9
HARDWARE & TOOLS PACK-----	10
ASSEMBLY-----	11
COMPUTER-----	18
ADJUSTMENTS-----	21
TROUBLE SHOOTING & MAINTENANCE-----	22
WARRANTY-----	23
PARTS REQUEST FORM-----	24

SERVICE

IMPORTANT: FOR NORTH AMERICA ONLY

For damaged or defective product, questions, replacement parts or any other service support, please contact our customer service department (8:00 AM - 5:00 PM Pacific Standard Time, Daily) by the below methods:

For Best Service, please Email:

Service@paradigmhw.com

Response Time: 1-2 Business Days

Website:

www.paradigmhw.com

Toll-Free:

1-844-641-7921

Response time may vary.

Please have the following information ready when requesting for service:

Your name

Phone number

Model number

Serial number

Part number

Proof of Purchase

For damaged or defective product please contact our customer service before returning to the store.

Paradigm Health & Wellness, Inc.

1189 Jellick Ave.

City of Industry, CA 91748, USA

LABEL PLACEMENT

<p>UNDER PENALTY OF LAMPHING TAG ALL NEW MATERIAL CONSISTING OF POLYURETHANE FOAM TAD: 100%.</p> <p>REGISTRY NO. VA25302 (CN)</p> <p>Certification is made by the California Bureau of Home Furnishings in this article are described in accordance with law.</p> <p>Paradigm Health and Wellness, Inc. 1189 Jellick Ave. City of Industry, CA 91748, USA</p>	<p>NOTICE</p> <p>This article does not meet the flammability requirements of California Bureau of Home Furnishings, technical bulletin 117. Care should be exercised in near open flame or with burning cigarettes.</p>
<p>SOUS PEINE DE SANCTION LEGALE, CERTIFICATION NE POUR ETRE ENTIEREMENT FABRIQUEE DE MOUSSE A FOAM TAD: 100%.</p> <p>NO D'ENREGISTREMENT VA25302 (CN)</p> <p>Cette étiquette est apposée conformément aux lois Californiennes.</p> <p>Paradigm Health and Wellness, Inc. 1189 Jellick Ave. City of Industry, CA 91748, USA</p>	<p>AVIS</p> <p>Ce produit ne satisfait pas aux critères d'inflammabilité spécifiés à l'article 117 du devis technique du California Bureau of Home Furnishings. Ne pas utiliser près d'une source de chaleur ou d'une flamme nue (cigarettes, etc.)</p>
<p>SE SANCONA LEGALMENTE A FOAM TAD: 100%.</p> <p>MATERIAL COMPLETAMENTE NUEVO COMPUESTO DE 100% RELENO DE ESPUMA DE POLIURETANO.</p> <p>NO. DE REG VA25302 (CN)</p> <p>El fabricante certifica que los productos descritos en esta etiqueta describen según las leyes.</p> <p>Paradigm Health and Wellness, Inc. 1189 Jellick Ave. City of Industry, CA 91748, USA</p>	<p>NOTIFICACIÓN</p> <p>Este artículo no se ajusta a la inflamabilidad requerida en el artículo 117. Cuidado de California deben ejercerse cerca de una llama abierta o con cigarets ardientes.</p>

The Crank will be damaged if the Right Tightened Pedal (59) into the Right Crank Counter. Left Crank Counter Clockwise

La manivelle pourrait être endommagée si les pédalles sont serrées dans le sens horaire (60) dans la manivelle gauche anti-horaire

Use diagram (59) in the right column to tighten the Right Pedal clockwise. Use diagram (60) in the left column to tighten the Left Pedal counter-clockwise.

Utilisez le diagramme (59) dans la colonne de droite pour serrer la pédale droite dans le sens horaire. Utilisez le diagramme (60) dans la colonne de gauche pour serrer la pédale gauche dans le sens anti-horaire.

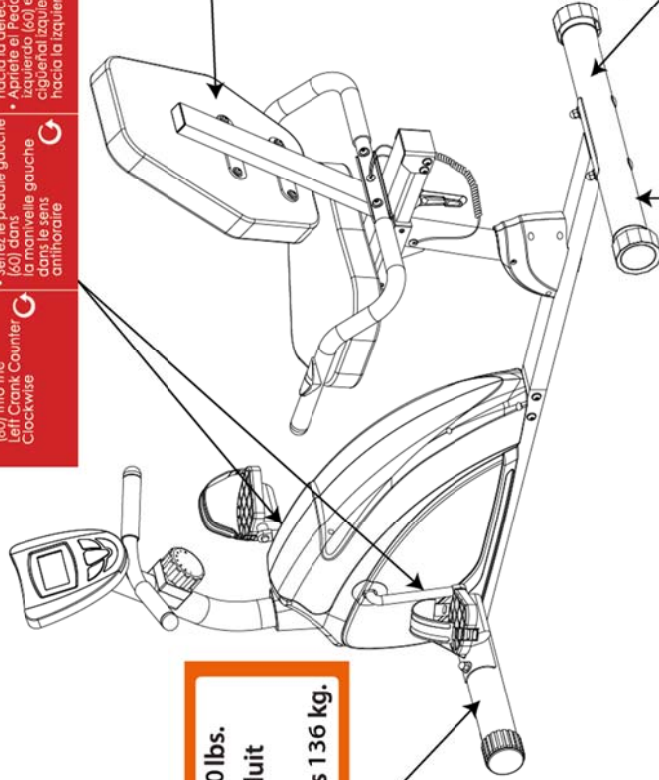

**Maximum weight capacity is 300 lbs.
Le poids maximum pout ce produit est 136 kgs.
La capacidad de peso máxima es 136 kg.**

EXERPEUTIC

For customer assistance, daily:
Pour le service à la clientèle
composer le, tous les jours:
Para servicios al cliente,
llame al, diario:

1-844-641-7921
8 am - 5 pm PST

8 90598011119

11406711100001

Serial number / Numéro de série / Número de serie:
MADE IN CHINA / FABRIQUÉ EN CHINE / HECHO EN CHINA

PRODUCT SAFETY

Basic precautions should always be followed, including the following safety instructions when using this equipment. Read all instructions before using this equipment.

1. Read all the instructions in this manual and do warm up exercises before using this equipment.
2. Before exercise, in order to avoid injuring your muscles, warm-up exercise for every muscle group is highly recommended. Please refer to the Warm Up pages for pre and post workout.
3. Please make sure all components are not damaged and in working order before use. This equipment should be placed on a flat surface while in use. Using a mat or other material on the ground is recommended.
4. Please wear proper clothes and shoes when using this equipment; do not wear clothes that get caught in any part of the equipment.
5. Do not attempt any maintenance or adjustments other than those described in this manual. Should any problems arise, discontinue use and consult an *Authorized Service Representative*.
6. Keep Dry - do not operate in wet or moist condition.
7. Always hold on to the handlebar while using the training bike.
8. To dismount, reduce pedaling speed gradually before you stop.
9. Do not use the equipment outdoors.
10. This equipment is for household use only.
11. Only one person should be on the equipment while in use.
12. Keep children and pets away from the product while in use. This machine is designed for adults only. This product requires a minimum of 6 feet of space for safe operation.
13. If you feel any chest pains, nausea, dizziness, or short of breath, you should stop exercising immediately and consult your physician before continuing.
14. **The maximum weight capacity for this product is 300 lbs/ 136 kgs.**

WARNING: Before beginning any exercise program consult your physician. This is especially important for the people who are over 35 years old or who have pre-existing health problems. Read all instructions before using any fitness equipment.

CAUTION: Read all instructions carefully before operating this product. Retain this Owner's Manual for future reference.

OVERVIEW DRAWING

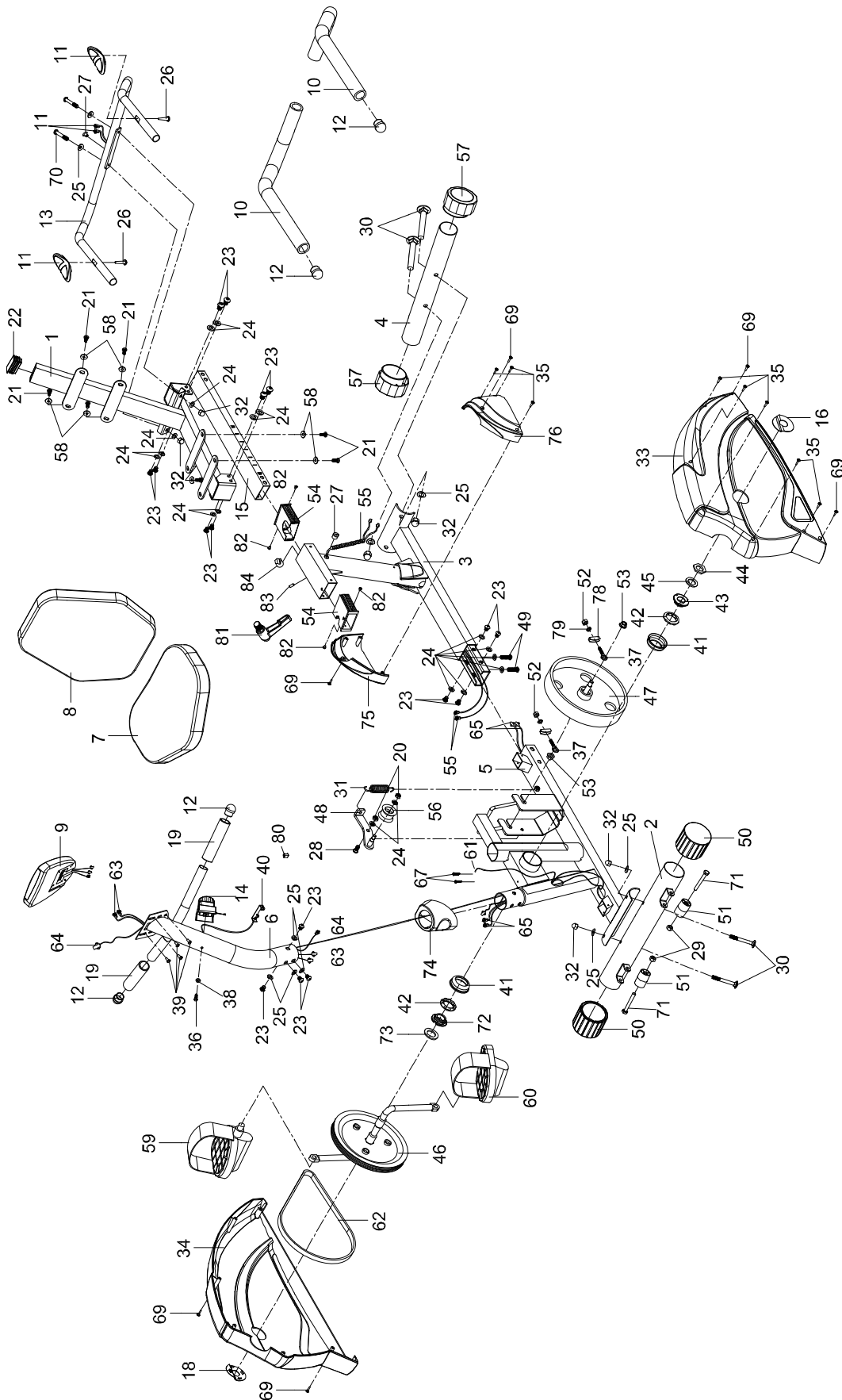

PARTS LIST

No.	Description	Qty	No.	Description	Qty
001	Back and Seat Support Bracket 53x23x2.0	1	028	Bolt M8x18	1
002	Front Stabilizer Ø60x1.5x580	1	029	Locknut M6	2
003	Rear Main Frame	1	030	Bolt M8x70	4
004	Rear Stabilizer Ø60x1.5x580	1	031	Spring	1
005	Front Main Frame 80x40x2	1	032	Cap Nut M8	6
006	Front Handlebar Post Ø50x1.5	1	033	Left Cover	1
007	Seat Cushion	1	034	Right Cover	1
008	Back Cushion	1	035	Screw ST4.2x25	8
009	Computer (JVT29121)	1	036	Bolt M5x25	1
010	Handlebar Foam Grip Ø30xØ24x510	2	037	Adjustable Bolt M6x33	2
011	Hand Pulse Sensor	2	038	Big Curve Washer Ø5	1
012	Round End Cap for Handlebar Ø25x1.5	4	039	Bolt M5x10	4
013	Handlebar Ø25x1.5	1	040	Tension Cable L=1000mm	1
014	Tension Control Knob	1	041	Axle Bush	2
015	Seat Sliding Tube 23x53x1.5	1	042	Bearing	2
016	Left Cover Cap Ø60xØ24x2	1	043	Axle Sleeve I 15/16"	1
018	Right Cover Cap Ø60xØ24x2	1	044	Nut 7/8"	1
019	Front Handlebar Foam Grip Ø30xØ24x160	2	045	Washer Ø34.5xØ23x25	1
020	Nylon Nut M8	2	046	Crank Ø200	1
021	Bolt M6x15	8	047	Flywheel Ø230	1
022	Backrest and Seat Support Bracket End Cap 23x53x1.5	1	048	Idle Wheel Bracket	1
023	Bolt M8x15	16	049	Bolt M8x30	2
024	Washer Ø8	18	050	Front Stabilizer End Cap Ø60	2
025	Curve Washer Ø8	10	051	Transport Wheel Ø23xØ6x32	2
026	Screw ST4.2x20	2	052	Nut M6	2
027	Wire Plug Ø12.1	2	053	Nut M10x1	2

PARTS LIST

No.	Description	Qty
054	Bushing	2
055	Middle Section Hand Pulse Sensor Wire	2
056	Idle Wheel	1
057	Rear Stabilizer End Cap Ø60	2
058	Washer Ø6	8
059	Right Foot Pedal YH-30X	1
060	Left Foot Pedal YH-30X	1
061	Sensor with Wire L=500mm	1
062	Belt 340J6	1
063	Extension Wire L=350mm	2
064	Extension Sensor Wire L=350mm	1
065	Extension Hand Pulse Sensor Wire L=1800mm	2
067	Pan Head Phillips Self Drilling Screw ST4.2x15	1
069	Pan Head Phillips Self Drilling Screw ST4.2x25	6

No.	Description	Qty
070	Bolt M8x45	2
071	Bolt M6x48	2
072	Axle Sleeve II	1
073	Washer 7/8"	1
074	Front Handlebar Post Cover	1
075	Right Rear Main Frame Cover	1
076	Left Rear Main Frame Cover	1
078	U Bracket	2
079	Spring Washer Ø6	2
080	Clip	1
081	Knob M16x1.5	1
082	Phillips Self-Tapping Screw ST4.2x6	4
083	Hex Screw M6x8	1
084	Baffle Plate	1

ASSEMBLY GROUP

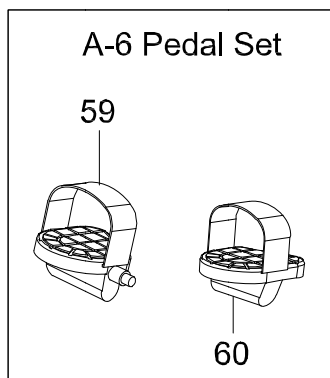
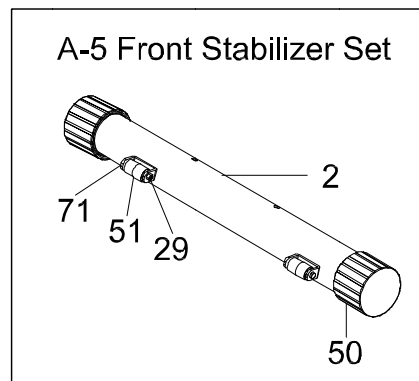
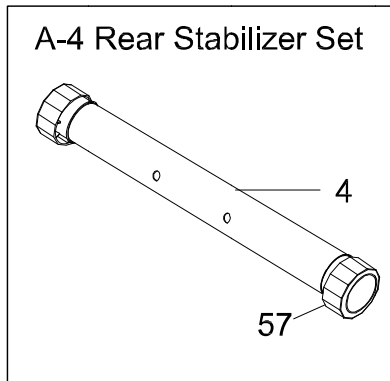
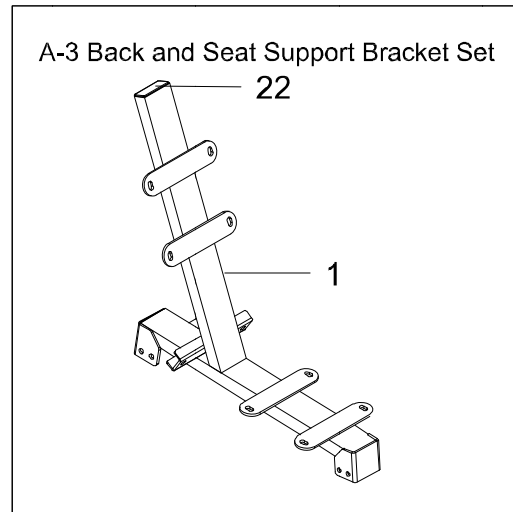
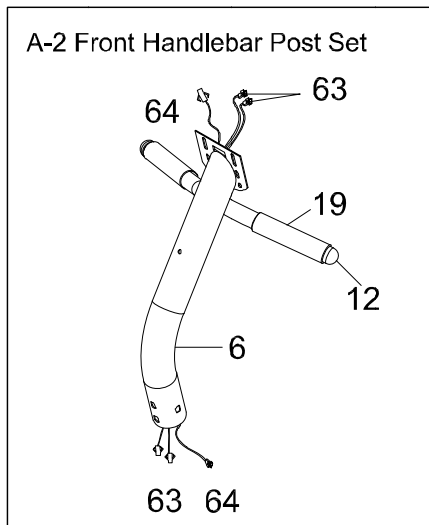
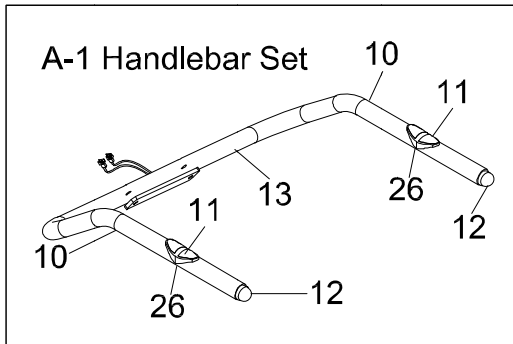

GROUP LIST

Assembly Group	No.	Description	Q'TY
A1	13	Handlebar Ø25x1.5	1
	10	Handlebar Foam Grip Ø30xØ24x510	2
	11	Hand Pulse Sensor	2
	12	Round End Cap for Handlebar Ø25x1.5	2
	26	Screw ST4.2x20	2
A2	6	Front Handlebar Post Ø50x1.5	1
	12	Round End Cap for Handlebar Ø25x1.5	2
	19	Front Handlebar Foam Grip Ø30xØ24x160	2
	63	Extension Wire L=350mm	2
	64	Extension Sensor Wire L=350mm	1
A3	1	Back and Seat Support Bracket 53x23x2.0	1
	22	Backrest and Seat Support Bracket End Cap 23x53x1.5	1
A4	4	Rear Stabilizer Ø60x1.5x580	1
	57	Rear Stabilizer End Cap Ø60	2
A5	2	Front Stabilizer Ø60x1.5x580	1
	29	Locknut M6	2
	50	Front Stabilizer End Cap Ø60	2
	51	Transport Wheel Ø23xØ6x32	2
	71	Bolt M6x48	2
A6	59	Right Foot Pedal YH-30X	1
	60	Left Foot Pedal YH-30X	1

HARDWARE & TOOLS PACK

1111-Hardware Pack

STEP 2

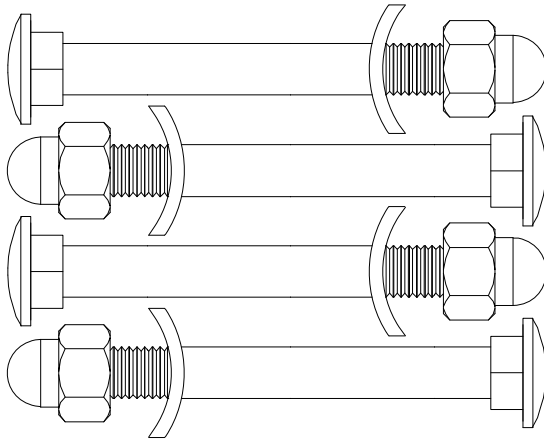

- #30 Bolt M8X70 4PCS
- #25 Curve Washer $\phi 8$ 4PCS
- #32 Cap Nut M8 4PCS

STEP 5

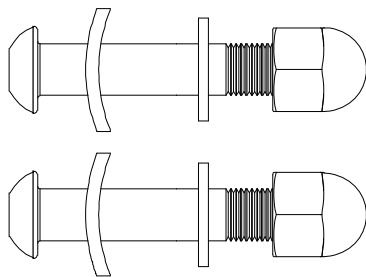

- #70 Bolt M8X45 2PCS
- #24 Washer $\phi 8$ 2PCS
- #25 Curve Washer $\phi 8$ 2PCS
- #32 Cap Nut M8 2PCS

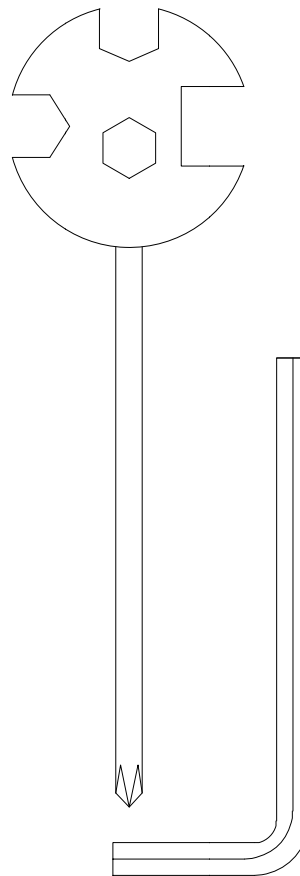

- Multi Hex Tool with Phillips
Screwdriver 1 PC
- Allen Wrench S6 1PC

ASSEMBLY

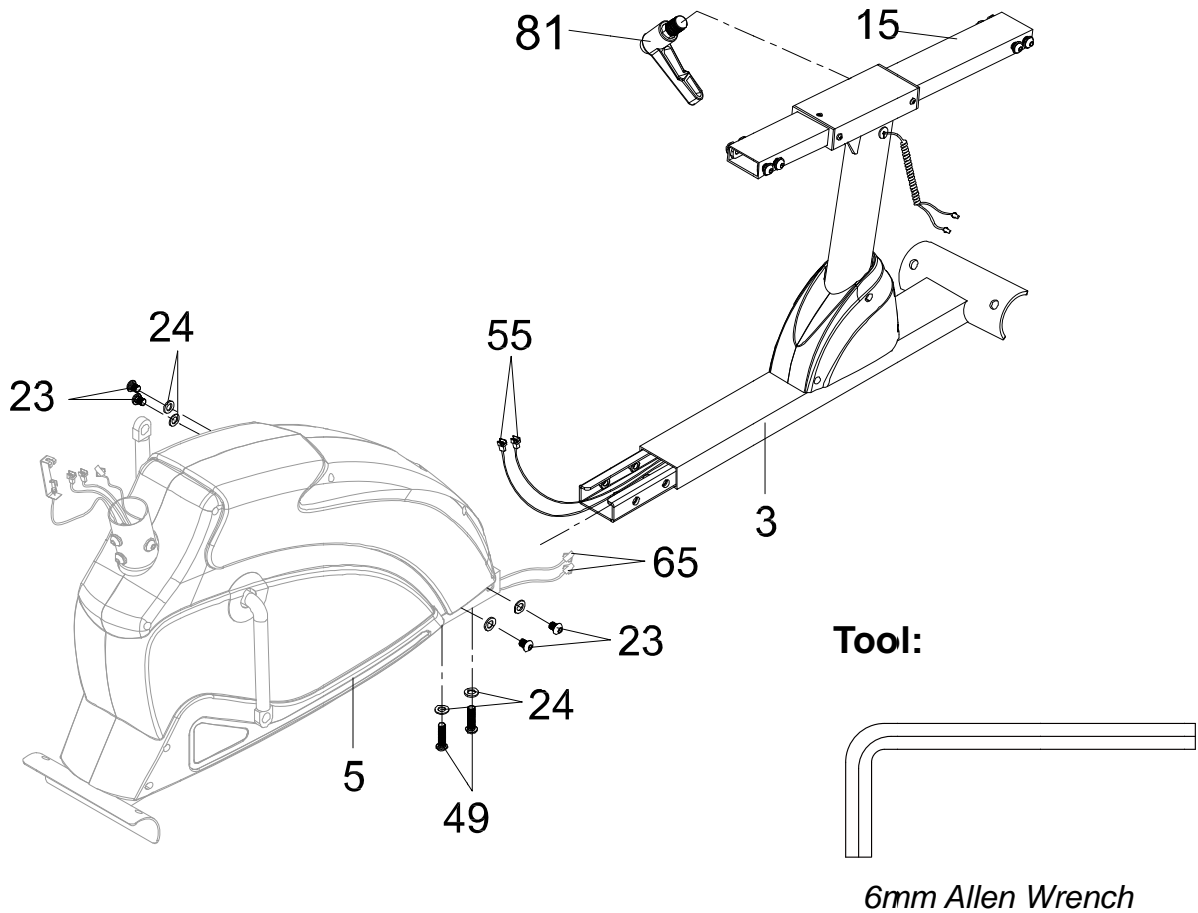

1. Rear Main Frame Installation

Remove two Bolts (49), four Bolts (23), and six Washers (24) from the Rear Main Frame (3). Remove bolts with the Allen Wrench provided.

Connect the Middle Section Hand Pulse Sensor Wires (55) from the Rear Main Frame (3) to the Extension Hand Pulse Sensor Wires (65) from the Front Main Frame (5). Attach the Rear Main Frame (3) into the Front Main Frame (5) with two Bolts (49), four Bolts (23), and six Washers (24) that were removed. Tighten bolts with the Allen Wrench provided.

Adjust the seat position and insert the Knob (81) in the clockwise direction to tighten.

ASSEMBLY

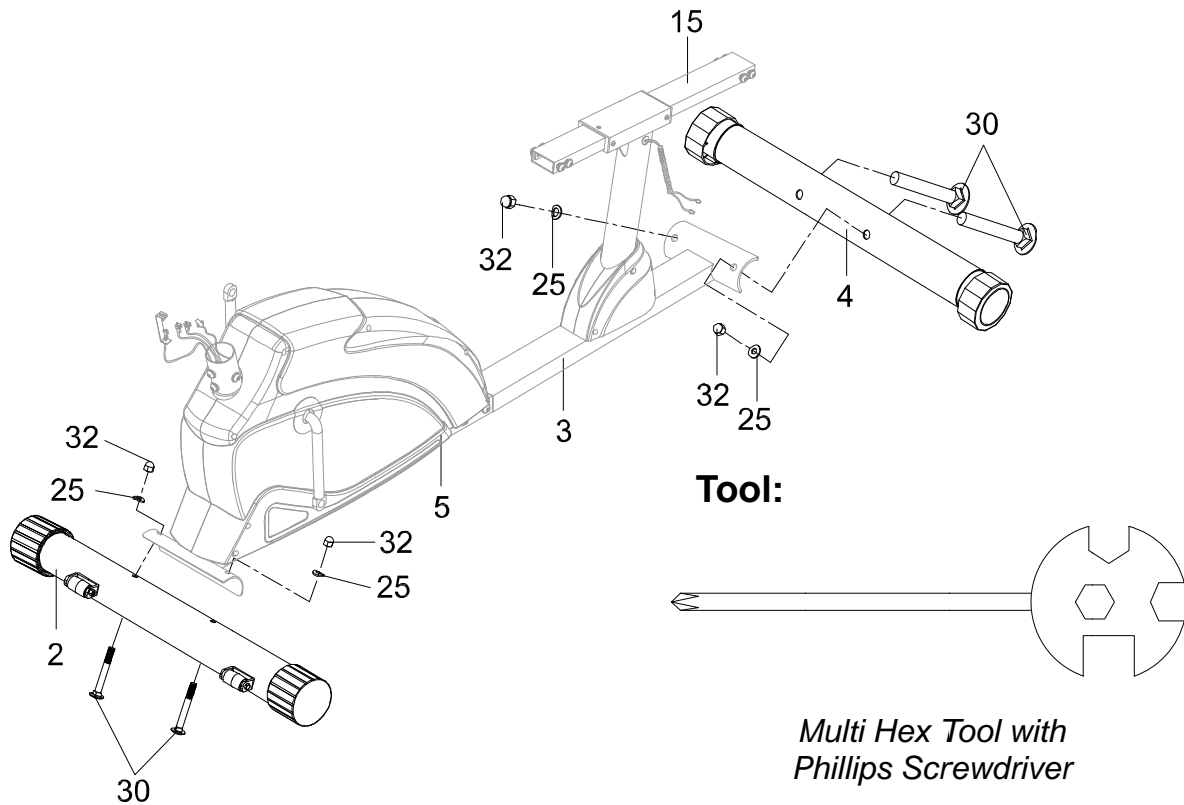

2. Front and Rear Stabilizers Installation

Position the Front Stabilizer (2) in front of the Front Main Frame (5) and align bolt holes. Attach the Front Stabilizer (2) onto the front curve of the Front Main Frame (5) with two Bolts (30), two Curve Washers (25), and two Cap Nuts (32). Tighten cap nuts with the Multi Hex Tool with Phillips Screwdriver provided.

Position the Rear Stabilizer (4) behind the Rear Main Frame (3) and align bolt holes. Attach the Rear Stabilizer (4) onto the rear curve of the Rear Main Frame (3) with two Bolts (30), two Curve Washers (25), and two Cap Nuts (32). Tighten cap nuts with the Multi Hex Tool with Phillips Screwdriver provided.

Hardware:

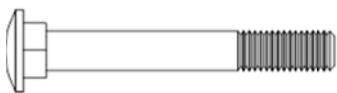

(30) Bolt
4 PCS

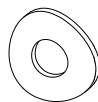

(25) Curve Washer
4 PCS



(32) Cap Nut
4 PCS

ASSEMBLY

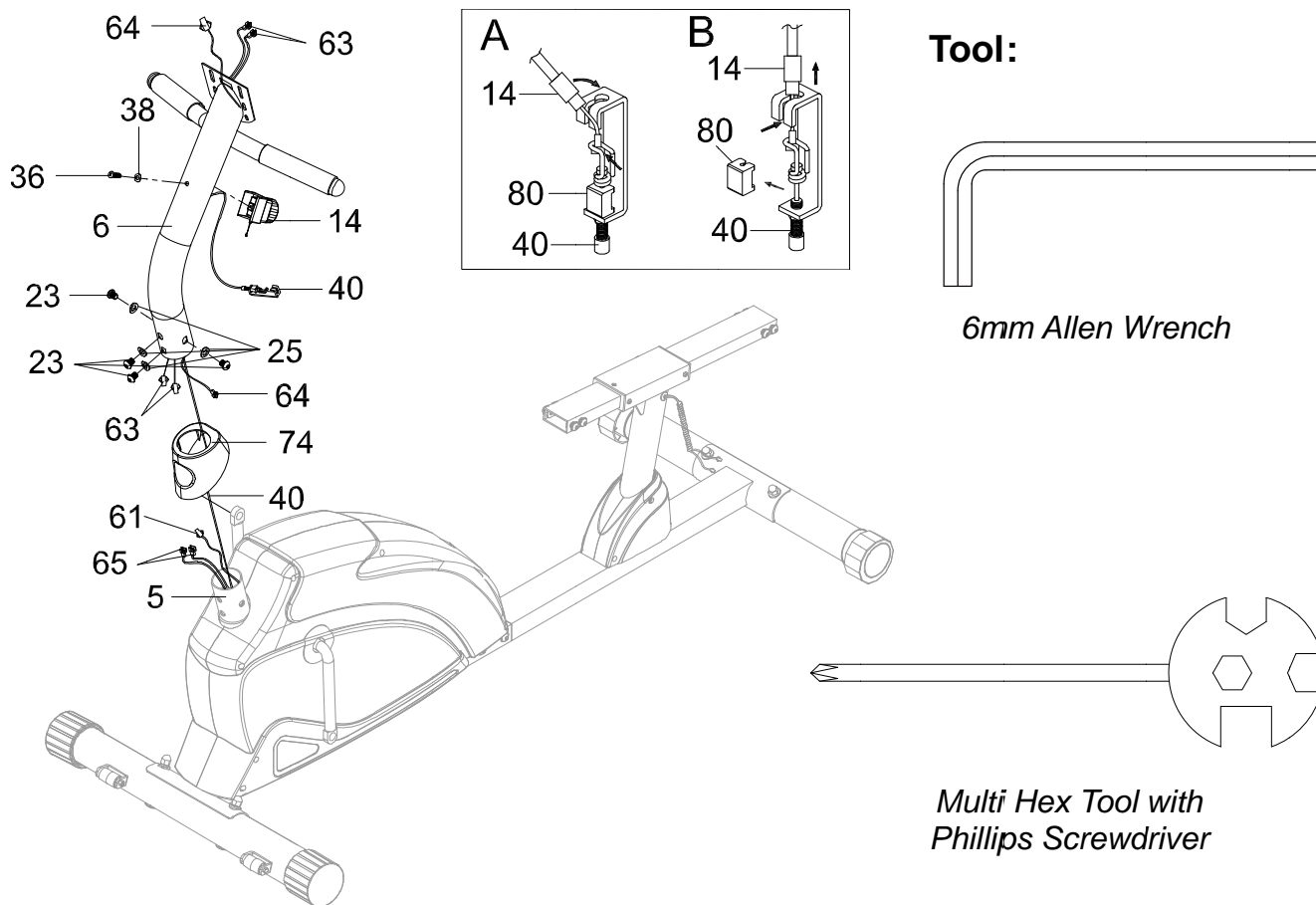

3. Front Handlebar Post and Foot Pedal Installation

Remove four Bolts (23) and four Curve Washers (25) from the Front Main Frame (5). Slide the Front Handlebar Post Cover (74) up to the Front Handlebar Post (6). Insert the Tension Cable (40) through into the bottom hole of Front Handlebar Post (6) and pull it out from the square hole of Front Handlebar Post (6).

Connect the Sensor Wire (61) and Extension Hand Pulse Sensor Wires (65) from the Front Main Frame (5) to the Extension Sensor Wire (64) and Extension Wires (63) from the Front Handlebar Post (6). Insert the Front Handlebar Post (6) onto the tube of the Front Main Frame (5) and secure with four Bolts (23) and four Curve Washers (25) that were removed. Slide the Front Handlebar Post Cover (74) down to the Front Main Frame (5). Remove the Bolt (36) and Big Curve Washer (38) from the Tension Control Knob (14).

Put the cable end of resistance cable of Tension Control Knob (14) into the spring hook of Tension Cable (40) as shown in drawing A. Pull the resistance cable of Tension Control Knob (14) up and force it into the gap of metal bracket of Tension Cable (40) and gently remove the Clip (80) after well-connected the resistance cable of Tension Control Knob (14) and Tension Cable (40) as shown in drawing B. Attach the Tension Control Knob (14) onto the Front Handlebar Post (6) with the Bolt (36) and Big Curve Washer (38) that were removed.

ASSEMBLY

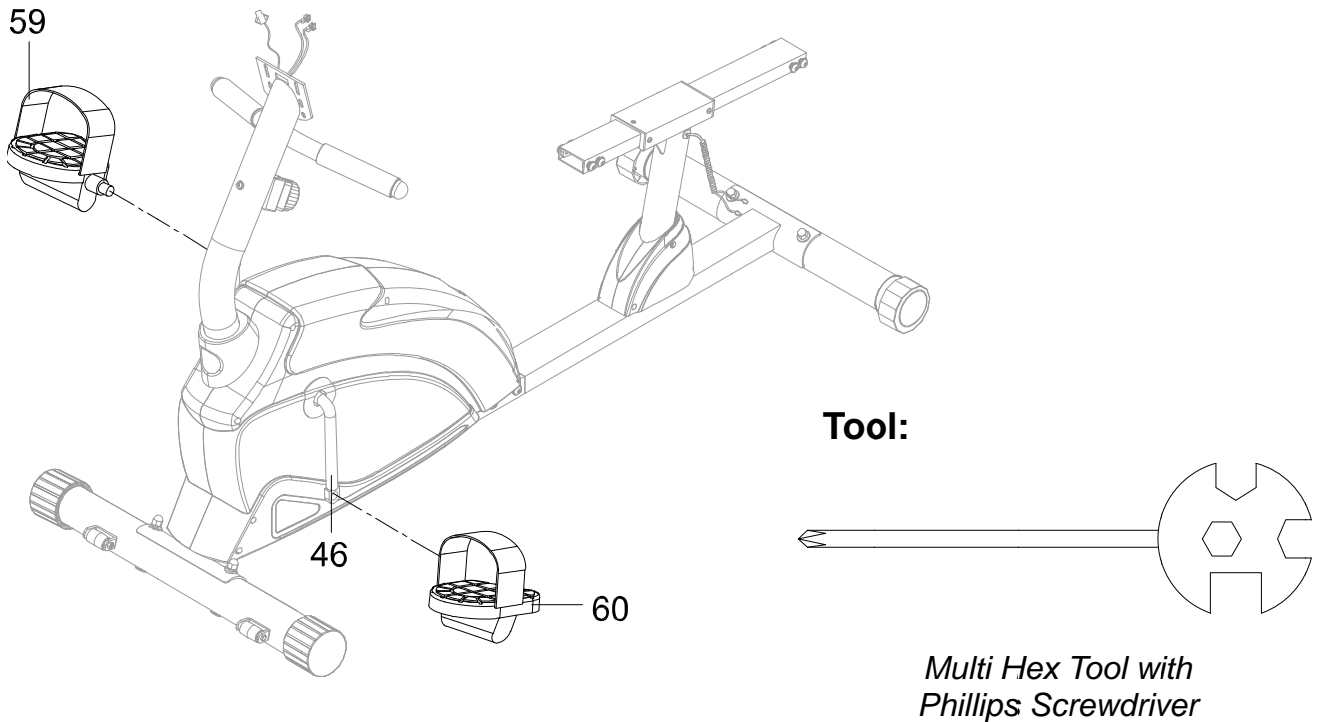

4. Right and Left Crank Installation

The Cranks, Foot Pedals, Pedal Shafts and Pedal Straps are marked “R” for Right and “L” for Left.

Insert the pedal shaft of Left Foot Pedal (60) into threaded hole in the left Crank (46). Turn the pedal shaft by hand in the counter-clockwise direction until snug.

Note: DO NOT turn the pedal shaft in the clockwise direction, doing so will strip the threads.

Tighten the pedal shaft of Left Foot Pedal (60) with the Multi Hex Tool with Phillips Screwdriver provided. Insert pedal shaft of Right Foot Pedal (59) into threaded hole in right Crank (46). Turn the pedal shaft by hand in the clockwise direction until snug. Tighten pedal shaft of Right Foot Pedal (59) with the Multi Hex Tool with Phillips Screwdriver provided.

ASSEMBLY

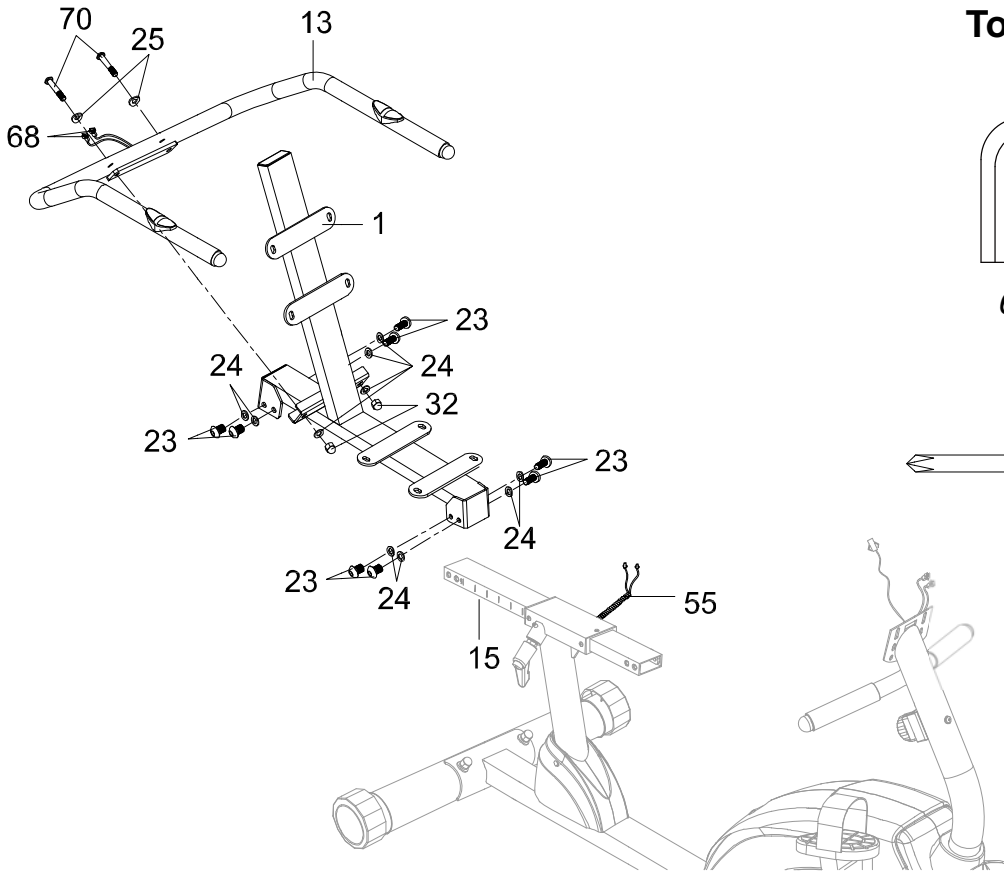

Tool:

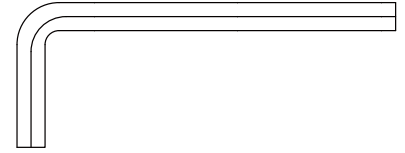

6mm Allen Wrench

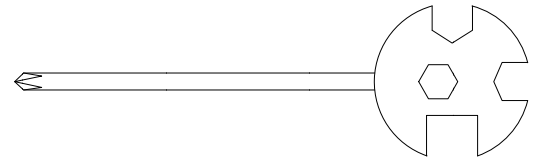

Multi Hex Tool with Phillips Screwdriver

5. Seat Sliding Tube, Back/Seat Support Bracket, and Handlebar Installation

Remove eight Bolts (23) and eight Washers (24) from the Back/Seat Support Bracket (1) and Seat Sliding Tube (15). Remove bolts with the Allen Wrench provided. Insert the Seat Sliding Tube (15) into the Bushings (54) of the Rear Main Frame (3). Attach the Seat Sliding Tube (15) to the Back and Seat Support Bracket (1) with eight Bolts (23) and eight washers (24) that were removed. Tighten bolts with the Allen Wrench provided.

Attach the Handlebar (13) onto the Back and Seat Support Bracket (1) with two Bolts (70), two Curve Washers (25), two Washers (24), and two Cap Nuts (32). Tighten bolts with the Multi Hex Tool with Phillips Screwdriver provided. Connect the Middle Section Hand Pulse Sensor Wires (55) from the Rear Main Frame (3) to the Hand Pulse Sensor Wire (68) from the Handlebar (13).

Hardware:

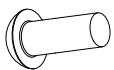

(70) Bolt
2 PCS

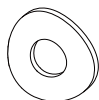

(25) Curve Washer
2 PCS



(24) Washer
2 PCS



(32) Cap Nut
2 PCS

ASSEMBLY

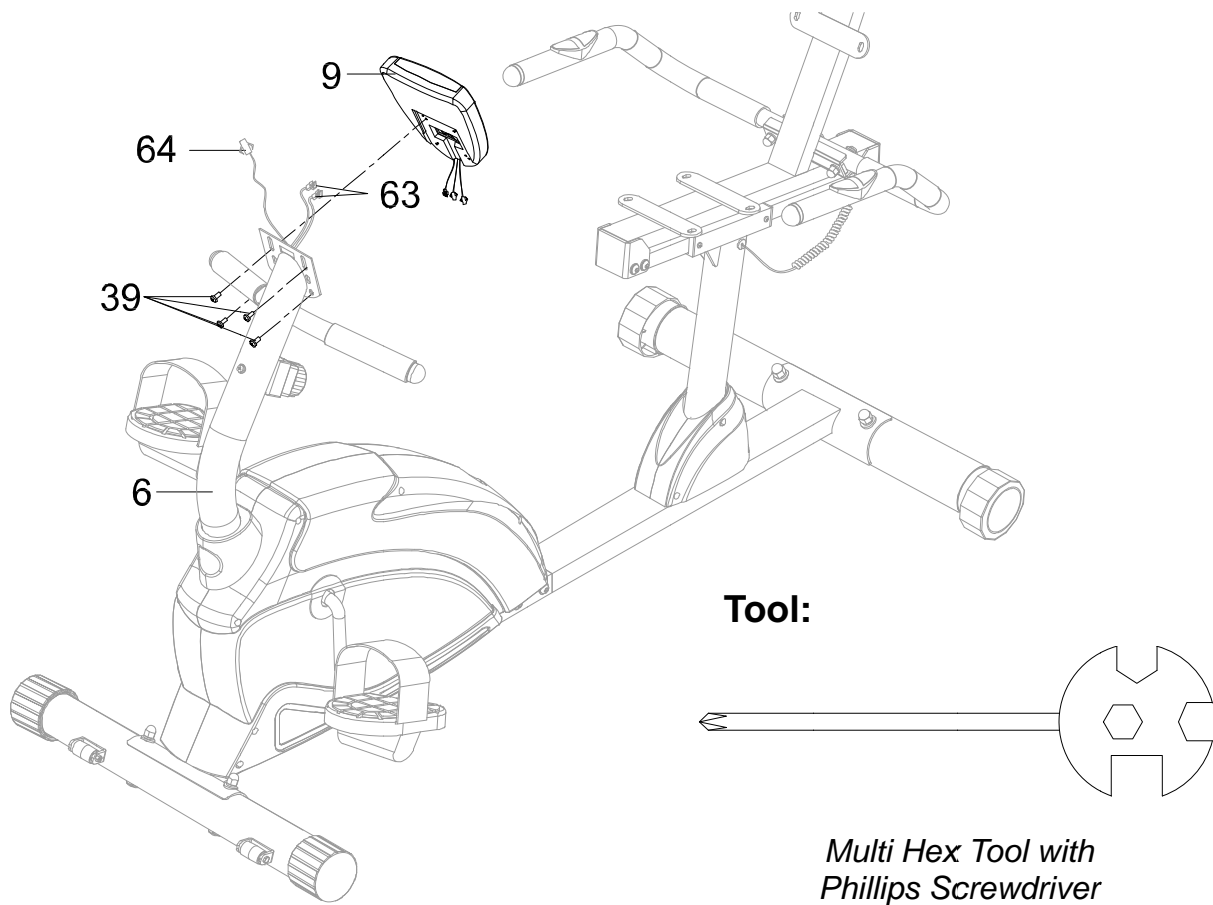

6. Computer Installation

Remove four Bolts (39) from the Computer (9). Remove bolts with the Multi Hex Tool with Phillips Screwdriver provided. Connect the Extension Wires (63) and Extension Sensor Wire (64) to the wires that come from the Computer (9). Tuck wires into the Front Handlebar Post (6). Attach the Computer (9) onto the top end of the Front Handlebar Post (6) with four Bolts (39) that were removed. Tighten bolts with the Multi Hex Tool with Phillips Screwdriver provided.

ASSEMBLY

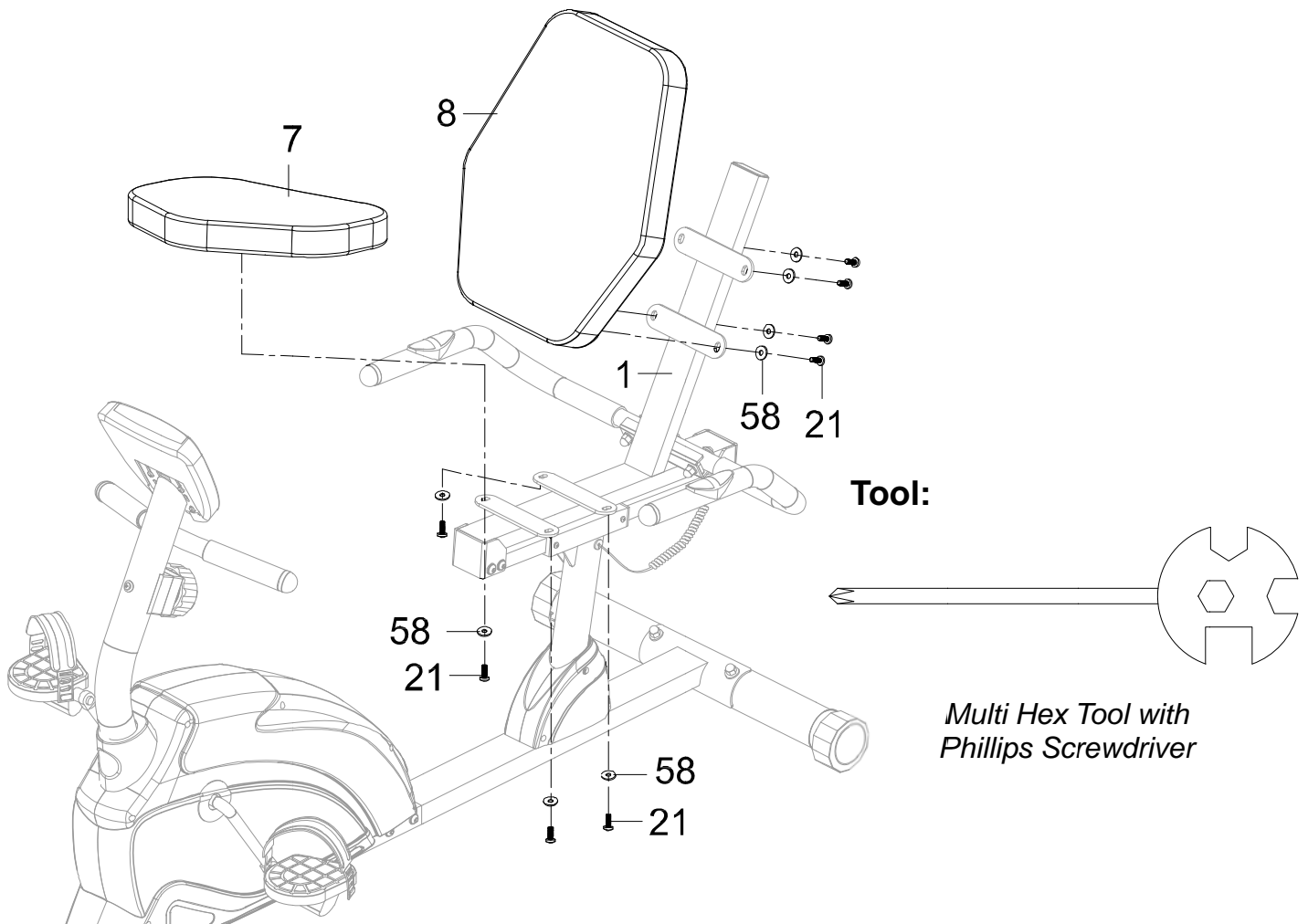

7. Seat and Back Cushions Installation

Remove eight Bolts (21) and eight Washers (58) from the back of the Seat and Back Cushions (7, 8). Remove bolts with the Multi Hex Tool with Phillips Screwdriver provided. Then attach the Seat and Back Cushions (7, 8) onto the Back and Seat Support Bracket (1) with eight Bolts (21) and eight Washers (58) that were removed. Tighten bolts with the Multi Hex Tool with Phillips Screwdriver provided.

COMPUTER

OPERATING THE COMPUTER

SPECIFICATIONS:

TIME -----	0:00-99:59 MIN: SEC
SPEED -----	0.0-999.9 MPH
DIST (DISTANCE) -----	0.0-999.9 MILE
CAL (CALORIES) -----	0.0-999.9 KCAL
ODO (ODOMETER) -----	0.0-999.9 MILE
♥ (PULSE) -----	40-240 BEATS/MIN



BUTTON FUNCTIONS:

MODE: Press MODE button to select each function of computer.

Press and hold MODE button for 3 seconds, all data values will clear to zero except the ODO (ODOMETER) data values.

SET: Press SET button to set data values of TIME, DISTANCE, CALORIES, or Pulse for target presetting.

RESET: Press RESET button to clear data values of TIME, DISTANCE, or CALORIES to zero.

Press RESET button to clear data values of TIME, DISTANCE, CALORIES, or Pulse to zero for target presetting.

Press and hold RESET button for 3 seconds, all data values will clear to zero except the ODO (ODOMETER) data values.

COMPUTER FUNCTIONS:

AUTO ON/OFF: When you start to exercise or press any key on the computer, the computer will turn on. If you leave the equipment for 4 minutes, the power will turn off automatically.

SCAN: Press MODE button until the screen displays a flash SCAN; the computer will automatically scan the function of TIME, SPEED, DIST (DISTANCE), CAL (CALORIES), ODO (ODOMETER), and ♥ (PULSE) every 6 seconds.

TIME: Press MODE button until the screen displays TIME; the computer will display your elapsed workout time in minutes and seconds. When you start to exercise, time starts counting up from 0:00 to 99:59 minutes per 1 second increment. You may also preset target time before training. Press MODE button to select TIME function and then press SET button to preset target time. Press RESET button to clear the target values of TIME to zero. The preset target time range is from 0:00 to 99:00 minutes. Once you preset target time and then start to exercise, time starts counting down from preset target time to 0:00 per 1 second backward. When the preset target time counts down to 0:00, time will start to count up immediately and the computer will begin beeping to remind you.



COMPUTER

SPEED: Press MODE button until the screen displays SPEED; the computer will display the current training speed.

DIST (DISTANCE): Press MODE button until the screen displays DIST; the computer will display the accumulative distance traveled during workout. When you start to exercise, distance starts counting up from 0.0 to 999.9 miles per 0.1 mile increment. You may also preset target distance before training. Press MODE button to select DIST function and then press SET button to preset target distance. Press RESET button to clear the target values of DISTANCE to zero. The preset target distance range is from 0.0 to 999.0 miles. Once you preset target distance and then start to exercise, distance starts counting down from preset target distance to 0.0 per 0.1 mile backward. When the preset target distance counts down to 0.0, distance will start to count up immediately and the computer will begin beeping to remind you.

CAL (CALORIES): Press MODE button until the screen displays CAL; the computer will display the total accumulated calories burned during workout. When you start to exercise, calories start counting up from 0.0 to 999.9 calories. You may also preset target calories before training. Press MODE button to select CAL function and then press SET button to preset target calories. Press RESET button to clear the target values of CALORIES to zero. The preset target calories range is from 0.0 to 999.0 calories. Once you preset target calories and then start to exercise, calories start counting down from preset target calories to 0.0. When the preset target calories count down to 0.0, calories will start to count up immediately and the computer will begin beeping to remind you. (This data is a rough guide for comparison of different exercise sessions and should not be used in medical treatment).

ODO (ODOMETER): Press MODE button the screen displays ODO; the computer will display the total accumulative distance traveled. The data values of ODO can not be clear to zero by pressing and holding MODE or RESET button for 3 seconds. If you take out the batteries from the computer, the ODO data values will clear to zero.

 **(PULSE):** Press MODE button until the screen displays a  symbol; the computer will display your current heart rate figures after you hold both two hands on handlebar grip sensors during exercise. To ensure the pulse readout is more precise, please always hold on to the handlebar grip sensors with two hands instead of just with one hand only when you try to test your heart rate figures. You may also preset target heart rate before training. Press MODE button to select  PULSE function and then press SET button to preset target heart rate. Press RESET button to clear the target heart rate to zero. The preset heart rate range is from 40 to 240 beats/minute. Once you preset target heart rate and then start to exercise, please hold both two hands on handlebar grip sensors during exercise. If the heart rate detected greater than the target heart rate, the computer

COMPUTER

HOW TO INSTALL THE BATTERIES:

1. Remove the battery cover at the rear of computer.
2. Place two "SIZE-AA" batteries into the battery housing.
3. Insure batteries are correctly positioned and battery springs are in proper contact with batteries.
4. Re-install the battery cover.
5. If the display is illegible or only partial legible, remove batteries and wait 15 seconds before reinstalling.

ADJUSTMENTS

Adjusting the Tension Control Knob

To increase the load, turn the tension control knob in a clockwise direction.

To decrease the load, turn the tension control knob in a counterclockwise direction.

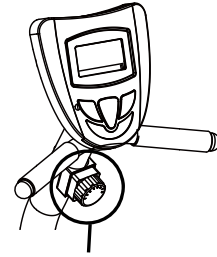

Tension Control Knob

Adjusting the Rear Stabilizer End Cap

Turn the rear stabilizer end cap on the rear stabilizer as needed to level the elliptical trainer

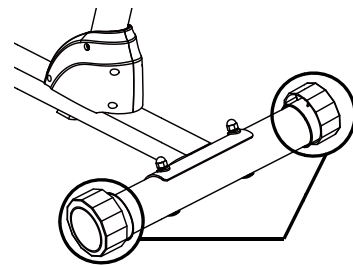

Rear Stabilizer End Cap

Adjusting the Seat Forward or Back

Turn the Knob (81) in a counter-clockwise direction until the seat can slide freely. Position the seat to a comfortable position and lock the seat in place by turning the knob (81) clockwise until tightly secured.

NOTE: When adjusting the seat back or forth direction, make sure the bushing does not exceed the mark line on the seat sliding tube.

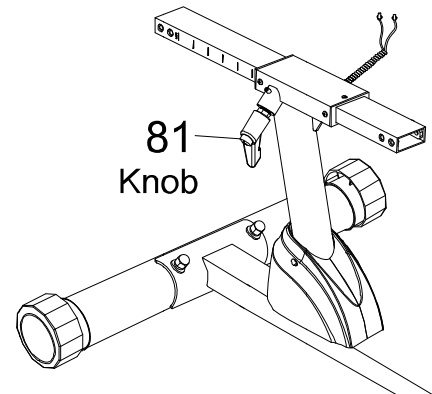

TROUBLE SHOOTING & MAINTENANCE

Cleaning

The recumbent bike can be cleaned with a soft cloth and mild detergent. Do not use abrasives or solvents on plastic parts. Please wipe your perspiration off the recumbent bike after each use. Be careful not get excessive moisture on the computer display panel as this might cause an electrical hazard or electronics to fail. Please keep the recumbent bike, specially, the computer console, out of direct sunlight to prevent screen damage.

Please inspect all assembly bolts and pedals on the machine for proper tightness every week.

Storage

Store the recumbent bike in a clean and dry environment away from children.

TROUBLESHOOTING

PROBLEM	SOLUTION
The recumbent bike wobbles when in use.	Turn the rear stabilizer end cap on the rear stabilizer as needed to level the recumbent bike.
There is no display on the computer console.	<ol style="list-style-type: none"> 1. Remove the computer console and verify the wires that come from the computer console are properly connected to the wires that come from the front handlebar post. 2. Check if the batteries are correctly positioned and battery springs are in proper contact with batteries. 3. The batteries in the computer console may be dead. Change to new batteries.
There is no heart rate reading or heart rate reading or is erratic / inconsistent.	<ol style="list-style-type: none"> 1. Make sure that the wire connections for the hand pulse sensors are secure. 2. To ensure the pulse readout is more precise, please always hold on to the handlebar grip sensors with two hands instead of just with one hand only when you try to test your heart rate figures. 3. Gripping the hand pulse sensors too tight. Try to maintain moderate pressure while holding onto the hand pulse sensors.
The recumbent bike makes a squeaking noise when in use.	The bolts may be loose on the recumbent bike, please inspect the bolts and tighten the loose bolts.

WARRANTY

MANUFACTURER'S LIMITED WARRANTY

Paradigm Health & Wellness warrants to the original purchaser that this product is free from defects in material and workmanship when used for the purpose intended, under the conditions that it has been installed and operated in accordance with Paradigm's Owner's Manual. Paradigm's obligation under this warranty applies to the following:

<u>COMPONENT</u>	<u>LENGTH OF WARRANTY</u>
Structural Frame	3 years
All Other Components (computer display, electronics, upholstery, foam, ball bearings, pulleys, belts, cables, wires, shocks, covers, tension, internal mechanism, wheels, pedals, knobs, accessories and hardware)	90 days

Exclusions from Warranty Coverage:

Paradigm does not warrant against and is not responsible for, and no implied warranty shall be deemed to cover, any product failure, product malfunction, or damages attributable to:

1. Improper installation and/or failure to abide by Paradigm's installation guidelines;
2. Use of this product beyond normal home use, or in an application for which it was not designed;
3. Cosmetic items such as scratches, dents or discolorations;
4. Damage caused by normal wear and tear, vandalism, accidental or by animals;
5. Any act of Nature (such as fire, flooding, snow, ice, hurricane, earthquake, lightning or other natural disaster), environmental condition (such as air pollution, mold, mildew, etc.), or staining from foreign substances (such as dirt, grease, oil, etc.);
6. Normal weathering due to exposure to sunlight, weather and atmosphere which can cause colored surfaces to, among other things, flake, chalk, accumulate dirt or stains.
7. Improper operation, alteration, handling, storage, abuse or neglect of the products.

Paradigm, using its sole discretion, will either repair or replace free of charge any part(s) proven to be defective under normal home use. Any repair or replacement shall provide no new warranty coverage, but shall retain only the remaining portion of the original product's warranty. This warranty is offered only to the original purchaser and is not transferable. Proof of original purchase is required.

Ordering Replacement Parts

Replacement parts can be ordered by emailing our customer service department:

Service@paradigmhw.com

Open Daily 8:00 AM - 5:00 PM (PST).

When ordering replacement parts please have the following information ready:

1. **Owner's Manual**
2. **Model Number**
3. **Description of Parts**
4. **Part Number**
5. **Date of Purchase**

